

bühnen SPIEGEL

Issue 48 · July 2024

... since 1976

Rothlehner
working platforms



Team Event in Pullman City

Company news

- ▀ Rothlehner Group Meeting in Pullman City

LIFT-MANAGER

- ▀ Bronto Service for aerial rescue platforms
- ▀ Service branch growing in Datteln
- ▀ NEW: Mobile service in the Oldenburg/Bremen area

GSR

- ▀ E290PX for HBV/Austria
- ▀ B220TJ on Atego 4x4

EASYLIFT

- ▀ NEW: RA15
- ▀ RA31 for Hobrack

DENKA-LIFT

- ▀ Old for new
- ▀ Koch replaces DK25
- ▀ New outfit

EuropeLift

- ▀ NEW: Cable remote control
- ▀ TM13T to Flott/Austria

Haulotte

- ▀ Platinum partner

News

- ▀ Moog bridge inspection platform for Slovakia
- ▀ Czech Republic team in country-music land

Dear Customer, Dear Bühnenspiegel Reader,

Current multiple crises are also not leaving us untouched, but we are directing our focus towards the future – also here in the new Bühnenspiegel.

To be able to shape this we are guided by a saying of a German politician: “Only those who know the past can understand and shape the future!”

These great words of August Bebel not only fit current world events but also the smaller entity of our corporate group.



We had enough reason to organise a large employee event following the best year in the history of our company with a turnover of € 56 million.

First, we had a get-together at our headquarters in Massing and afterwards in the **western park Pullman City** - where around 180 of a total of 230 employees participated.

Many reasons to say thank you for many years of involvement in the success of the company and a chance to reflect - where we come from, where we are and where we are going!

This company event was also a great opportunity to outline the current status to employees regarding the generation change within our group of companies.

In the Czech Republic, Marek Tomasek took over the management from his father Zbynek in March this year already. Zbynek Tomasek remains active in the company and is responsible for special truck projects.

At Lift-Manager GmbH, Silvana Jäkel and Robert and Thomas Rothlehner are joining the Management and will manage the company together with Roland Jäkel.

In the German Rothlehner Arbeitsbühnen GmbH, with its 30-year branch in Austria, Thomas and Robert Rothlehner will manage the company together with Manfred Rothlehner.



On the left, the participating Polish team at the entrance to Pullman City in Eging.



Jozsef Merva, who has had general commercial power of representation up until now, has been appointed as managing director and will lead the company together with Manfred Rothlehner.

In Slovakia - see team photo right - Laco Kajan continues to manage the company and he and his team are already looking forward to the newly planned hall with workshop and offices in Nitra.



The setting of the impressive western city and the professional care on-site made a decisive contribution to the success of this company event.

Many thanks to all participants, the organisation teams and to the staff of the western city!

Manfred Rothlehner
 Rothlehner Arbeitsbühnen GmbH

Roland Jäkel
 Lift-Manager GmbH

BRONTO - Service for aerial rescue platforms

Lift-Manager continues to expand service for **BRONTO** aerial rescue platforms.

Whether airports, industrial companies or municipalities, the workshop doors at Lift-Manager are regularly opened for various **BRONTO** firefighting aerial rescue platforms.



F32RLX of Airport Ostrava



F53RL of City of Munich



F42RL of Fire Brigade Weiz, Austria

The trained **BRONTO** team at Lift-Manager is commissioned for both short-notice maintenance and repair works, and also long-term planned 10-year checks which are specified based on standardised procedures.

Regular training courses are carried out to keep our service technicians up to date.

In May, a technical training course took place in Finland. Along with service manager Carol Buder, technicians from Jänkendorf, Datteln, Breitenfelde and Massing also took part.

Naturally, the competency gained here also contributes towards being able to provide repairs and general restorations on truck-mounted lifts and large-scale machines from other manufacturers. Please direct any inquiries to Mr Carol Buder (bc@lift-manager.de 0049 3588 254618).

We were able to admire the production process and the impressive boom blank parts in more detail during a little trip to the **BRONTO** plant in Pori.



Service branch continues to grow in Datteln

Lift-Manager continues to develop their branch in Datteln.

The Lift-Manager service team in Datteln are moving just around the corner to gain better access and significantly more space.

1,200 m² workshop space will be available for the maintenance and repairs also for the large-scale, self-propelled machines and **BRONTO** trucked-mounted machines.

From July, you can find the branch in Datteln here:

Industriestraße 11, 45711 Datteln



Mobile service now also in the Oldenburg area

Since March, there has been a mobile service technician active in the extended area of Oldenburg/Bremen.

René Jansen is now looking after the North-West area with an extensively equipped Mercedes Sprinter.

Handover of GSR E290PX

A **GSR E290PX** on MAN was recently delivered to the Austrian, family-run company **HBV Arbeitsbühnen Vermietung GmbH**.

As SystemLift partner, the company of Wilfried Nussbacher with a team of 16 employees, hires around 250 working platforms and forklifts.

This machine is replacing a one of the same construction type which has reliably performed since 2009.

The machine was delivered and handed over to the owner Wilfried Nussbacher (photo right) in Feldkirchen near Graz by Bernhard Spörk from Rothlehner Austria.



Rothlehner wishes HBV every success with this new machine!



GSR E290PX Comfort X

The **E290PX Comfort X** has been a well-established 7.5 t articulated, telescopic work platform by GSR for many years.

The E290PX is an alternative to the classic telescopic construction type with a working height of 28.70 m and 15.50 m lateral reach at a basket load of 220 kg and simultaneously a minimal outrigger width.

Thanks to the high articulation point of 11 m, the E290PX also overcomes high roof canopies and other obstacles. Alternatively, basket loads of 250 kg or 280 kg are available.

Besides the 7.5 t Mercedes, MAN and IVECO carrier vehicles, there are further weight variants and also all-wheel drive versions in the range.

Delivered: GSR B220TJ on Mercedes Atego 4x4

We were recently able to handover two **GSR B220TJ 4x4** to customers.

A forestry service provider and utility company are already benefiting from the advantages of the high all-terrain capability of this 22 m working platform.

The extremely high outrigger lift permits work also in difficult terrain, various tonnages between 7.5 and 11 t are available.



Netz Leipzig GmbH is stepping up to increasing challenges with an all-terrain, truck-mounted **GSR B220TJ on Mercedes Benz 7.5t 4x4** working platform.

Rothlehner would like to thank you for your trust and wish the team at Netz Leipzig GmbH many successful deployments.



Innovation: Easy-Lift RA15

EASYLIFT
EASYLIFT
EASYLIFT

R130

RA15

R160

R180

R190



The **RA15** from **EASYLIFT** has been completely newly developed.

R210

The compact spider-lift with a working height of 14.90 m and a total length of 4.20 m is 30 cm shorter than the previous model. The new double-articulated boom enables 230 kg basket load across the entire working range and the fully hydraulic control system has been adopted from the well-established R130 – R180 models. There is also an extensive range of special equipment available from **EASYLIFT** for the RA15. The compact RA15 can be optimally equipped for every deployment purpose with petrol, diesel and battery drive variants, convenience features such as automatic outriggers and radio remote control and many further options.

RA24

RA26

Easy-Lift RA31 goes to Hobrack Arbeitsbühnenvermietung

R260

Hobrack Arbeitsbühnenvermietung GmbH, founded by Ronald Hobrack, recently received an **EASYLIFT** RA31 track-mounted working platform. The performance data of this machine was convincing: 89 cm minimum clearance width, 300 kg maximum basket load with a weight of only 4,400 kg. Likewise, the high reach-over point of the articulation, the maximum reach of 14.50 m and the hybrid drive of Kubota diesel and lithium battery.

R300

We wish Hobrack Arbeitsbühnenvermietung many successful deployments with their RA31 **EASYLIFT** crawler lift.

RA31

R360

R420

RA53



Steve Hobrack, son-in-law of company founder Ronald Hobrack, takes receipt of the new RA31.

Exchange old for new

Years and decades of use take their toll even on DENKA•LIFTs which are renowned for their longevity.

Since 2013, the DENKA•LIFT trailer-mounted lifts which are popular with hire companies and end users have been produced by Rothlehner in Germany. The stable aluminium telescopic booms provide users with the best performance data, safe and convenient working at height and astonishing outreaches. And a minimal total weight of the machine.

Rothlehner as manufacturer and Lift-Manager as service provider offer a multitude of options for the aging machines:

We offer new DENKA•LIFT machines from 18 to 30 m working height with various options.

We swap machines old-for-new, in part-exchange or for purchase.

We support you as a service partner and will happily care for your working platform with a maintenance contract.

We will also renovate your machine(s) according to your wishes - happily also your DENKA-Junior.



Koch-Arbeitsbühnen replaces DK25

The delivery of a new DENKA•LIFT DK25 to PartnerLift company **Arbeitsbühnen Koch GmbH** and the part-exchange of an older model of the same construction type serves as an example of first-class business.

This friendly business relationship between Koch and Rothlehner stretches back to the 1990s, when Manfred Rothlehner delivered the first DENKA•LIFT to the Koch family in Leipzig.

The high-performance manoeuvring drive and sensitive proportional controls as standard level equipment is supplemented by a high-value paint finish in own-brand colours, with automatic outriggers and permanently mounted LED rear lights of the work basket.

We thank the Koch family as our longstanding customer for their trust and wish them many years of successful deployments with the new DK25.



A new outfit for your DENKA•LIFT

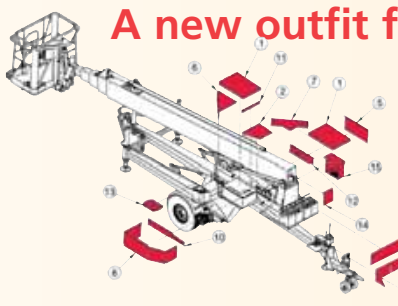

Lift-Manager provides different trim kits for the DENKA chassis types DK7 and DK3 (18 and 25m machines) at a special price.

These comprise of up to 14 or 16 trim parts, painted in DENKA red RAL 3002.

Please send inquiries to: ersatzteile@lift-manager.de

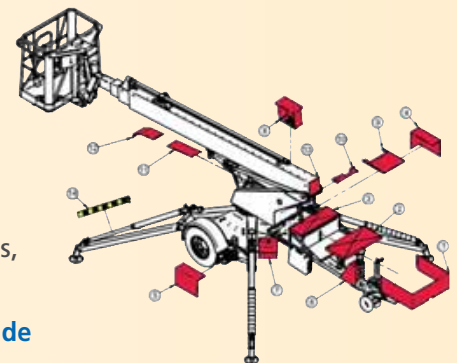

EuropeLift trailer-mounted working platforms now with optional cable remote control

The **cable remote control** special equipment for manoeuvring drives and outrigger functions is newly available.

Instead of the standard, fully hydraulic drive activation on the tow bar, the working platform can now easily be moved at an optimal distance to the machine in this way.

Sensitive manoeuvring is possible thanks to two proportional joysticks which is important for narrow clearances, for example. The **automatic levelling function** newly developed for the GTi model series is likewise controlled by remote control.



Third TM13T delivered to Flott

FLOTT Arbeitsbühnen GmbH in Lieboch near Graz hires working platforms and forklifts.

Rothlehner has enjoyed top-class collaboration with the company for more than 20 years.

Besides many **DENKA•LIFTs** and other machines from Rothlehner, the team around managing director **Bernd Stroißnig** has also taken several EuropeLift TM13T into their fleet over the past years.

Within the scope of the MAWEV Show, a third EuropeLift TM13T – telescopic, trailer-mounted platform with jib - was handed over to Mr Stroißnig of FLOTT Arbeitsbühnen GmbH.

Photo: Bernd Stroißnig (right) receives the TM13T from Bernhard Spörk (Rothlehner Austria)

Haulotte platinum partner

This year, the Rothlehner Group was distinguished as a **Haulotte Platinum Partner**, the highest category for collaboration with Europe's market-leading manufacturer.

More than 20 years of close collaboration in sales and service connects these two companies.

This means, approximately 4,000 new machines have been sold and technical service provided nationwide in Germany, Austria, Czech Republic, Poland and in Slovakia.

In February 2024, a sales partner meeting took place at Haulotte in Lorette, France with representatives of the Rothlehner Group from these countries.

It became clear during this meeting that mutual appreciation forms the basis of this excellent collaboration.



Haulotte and Rothlehner team

MOOG – Bridge inspection platform

At the end of May, an **MOOG bridge inspection platform MBI 110-1.2S** on Iveco Eurocargo ML190 with a total weight of 19,000 kg was delivered to "Regionalwege Košice" **Správa ciest Košického samosprávneho kraja** in Slovakia.



This fully equipped machine includes a 20 kVA generator with Hatz diesel engine, air and water lines in the basket, Maxilift 180 crane with special hook and an extension of 2.00 m, and an additional compressor and 400 V drive.

The customer uses the platform themselves for bridge repairs and also hires it out to other state-owned companies in Slovakia.

Czech team in Pullman City



Our Czech company took part with around 60 employees at the Rothlehner Group event at the beginning of June.

As well as the wide range of highlights of the Pullman City western city, Zbynek Tomasek, who has run the Czech company for over 30 years, took the opportunity to play into the small hours at the "Rothlehner Area" with friends in their own country music band.



Contact Abroad:

Österreich, Slowenien, Kroatien
Bernhard Spörk

Packerstraße 7
A-8561 Söding
Tel. +43 664 3364030
info@rothlehner.at
www.rothlehner.at

Tschechien
Marek Tomásek

Mezi uvozy 2512/2a
CZ-19300 Praha 9
Tel. +420 2 81090590
Fax +420 2 81090596
info@rothlehner.cz
www.rothlehner.cz

Slowakei
Ladislav Kajan

Novozamocká 102
SK-949 01 Nitra
Tel. +421 37 6525520
Fax +421 37 6525522
info@rothlehner.sk
www.rothlehner.sk

Polen
Manfred Rothlehner

ul. Energetyków 4
PL-32-050 Skawina
Tel. +48 12 2675811
Fax +48 12 2675811
info@rothlehner.pl
www.rothlehner.pl

Rothlehner working-platforms

Product Range

- ▶ Trailer-mounted up to 30m
- ▶ Truck-mounted
- ▶ Scissor-technology and self-propelled
- ▶ Specialised narrow equipment
- ▶ Crawler mounted
- ▶ Used equipment

Services

- ▶ Consulting
- ▶ On-site customer service
- ▶ Spare part service
- ▶ Oil filtration, bio-oil
- ▶ General maintenance
- ▶ Project planning
- ▶ Finance
- ▶ Insurance
- ▶ **IPAF**-training centre

Location:



Everything under one roof

Impressum:

Editor and head office:
Rothlehner Arbeitsbühnen GmbH

Mühlenweg 1
D-84323 Massing-Oberdietfurt
Tel. 0 87 24 / 96 01-0
Fax: 0 87 24 / 96 01 -12
info@rothlehner.de
www.rothlehner.de

Layout:
Franz Fürstberger
LOGO! Design und mehr ...

Redaktion:
Manuel Miller, Fred Rothlehner

current range of second hand & stock machines

If interested, please mark devices in checkboxes and return to us with the "send" button on page 2



21838 - Easylift RA15
15m -230V&Petrol- year '24



23850 - Europelift TM13G Eco
13m -230V&Petrol - Bj. 2024



23135 - GSR B220TJ
22m - Diesel - year 2024



8672 - Haulotte HA15IP
15m - Battery - year 2005



26056 - Europelift TM16GT
15,8 - 230V & Petrol - 2023



18014 - GSR B180T
17,7m - Nissan 50k km - 2024



more units available !

25095 - Haul. Compact 12
12m - Battery - year 2021



11991 - DENKA DL30
30m - Battery - year 2007



26174 - EasyLift R180
18m -230V & Petrol - 2023



19883 - GSR B220TJ
22m - MB 15k km - year '21



24783 - JLG 510AJ
17,8m - 4x4 Diesel - year '14



22741 - Haulotte Star 8S
7,95m - Battery - year 2021



3525 - PB Dino 1210
12m - Battery - year 2002



26033 - Haul. Optimum 8
8m - Battery - year 2021



3201 - DENKA DL28N Narrow
28m - Battery - year 2001



25101 - Haulotte Star10
10m - Battery - year 2021



22848 - GSR E290PX
28,2m - MAN TGL - year '24



26042 - Easylift RA 31
31m - Battery & Diesel - '24



more units available !

24769 - Haulotte Compact 8
8m - Battery - year 2013



25774 - Easylift R130
13m - 230V&Petrol -Bj.2024



24387 - Haul. Compact 12DX
12m - Diesel 4x4 - 2007



more units available !

24779 - Haul. Compact 10
10,00m - Battery - year 2007



8893 - DENKA Dk18
18m - Battery - Bj. 2013



more units available !

24759 - Haulotte Star10
10m - Battery - Bj. 2013



7413 - DENKA DL18
18m - Battery - year 2006

Subject to prior sale

More machines upon request or visit us online:

Your personal response-form

We wish ...

Our E-Mail-address:

Our Internet-address:

Contact person

Please fill in address and contact person

I'm interested in:

New DENKA•LIFTS



DK 18

DK18



DK 25

DK25

Basket on the rear



DL 18/21

DL18/21



DL 25/30

DL25/30

Basket in front

 Used DENKA•LIFTS, type _____

 DENKA•LIFT Spare parts
 Technical support

I have used DENKA•LIFTS for sale or to replace: type _____

We are interested in used machines, please offer:

trailer platforms special narrow machines scissor platform selfpropelled

Please send next bühnenSPIEGEL by post or by email no more

Fax +49 8724 960112
E-Mail info@rothlehner.com

... since 1976
Rothlehner
working platforms